



Université de Lorraine - UR 4366

Pôle Scientifique « Energie Mécanique Procédés Produits »

Groupe de Recherche en Energie Electrique de Nancy

Séminaire Scientifique du GREEN

**Comparison of methods for evaluating mechanical stress
in the rotor of high-speed machines**

Larbi Dahnoun

12 septembre 2022

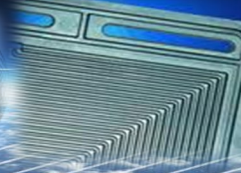
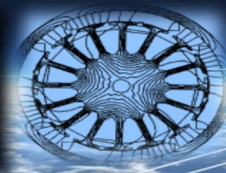

- Classic topology of electrical generation with three stages

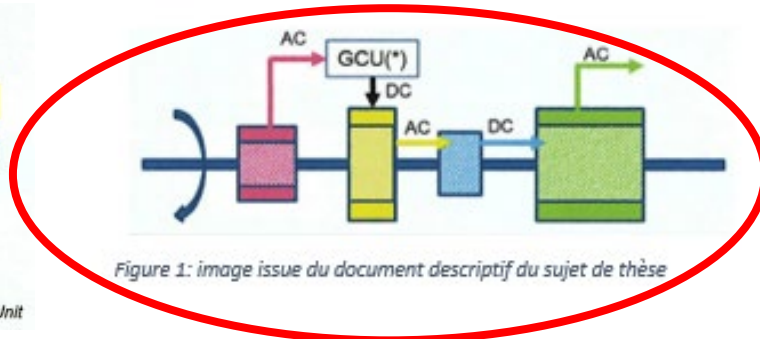
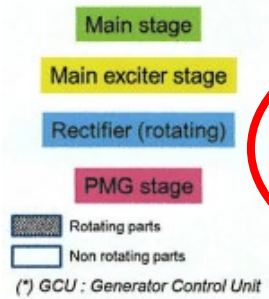

Figure 1: image issue du document descriptif du sujet de thèse

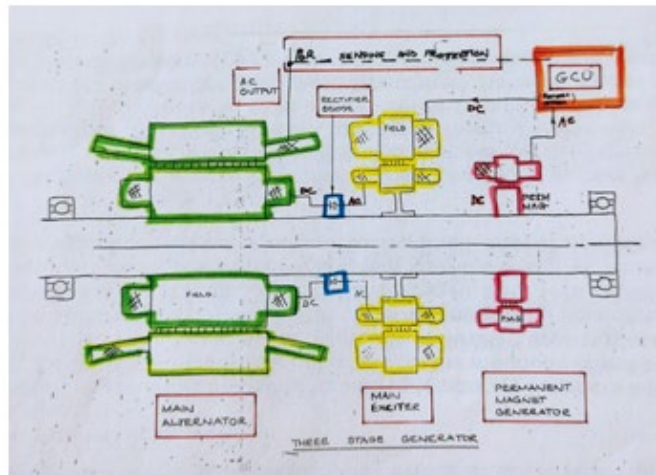
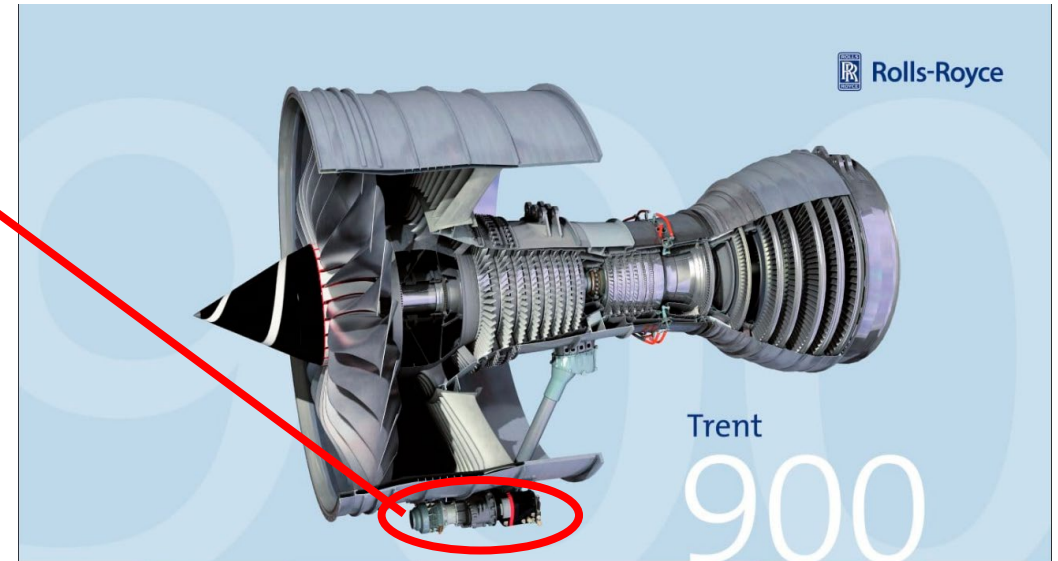
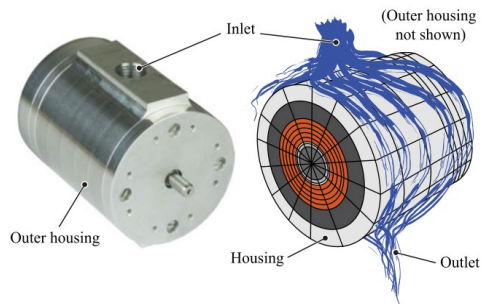

Figure 3: système d'excitation avec PMG (source: SAFRAN Power UK/USA, interne)



- Increasing enthusiasm for high-speed machines to increase **electrical power density**
- Develop a **multiphysic model** for high-speed electrical machine



Thermal management

Picture from: A. Tuysuz, F. Meyer, M. Steichen, C. Zwysig, et J. W. Kolar, « Advanced Cooling Methods for High-Speed Electrical Machines », IEEE Trans. on Ind. Applicat., vol. 53, n° 3, p. 2077-2087, mai 2017, doi: 10.1109/TIA.2017.2672921.

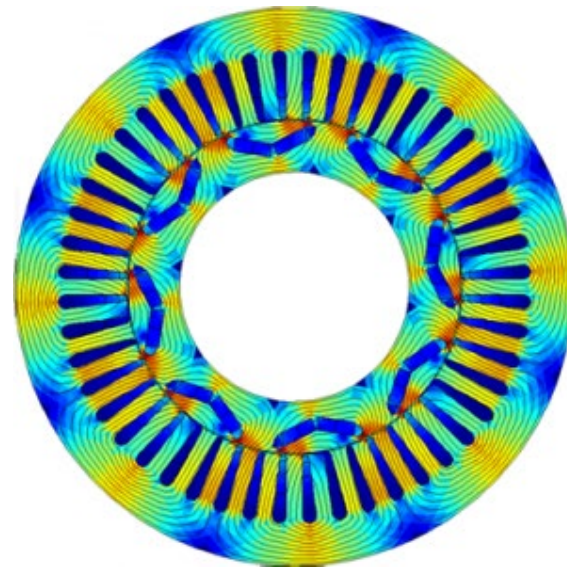

Electromagnetic design

Picture from: www.motoranalysis.com/support/

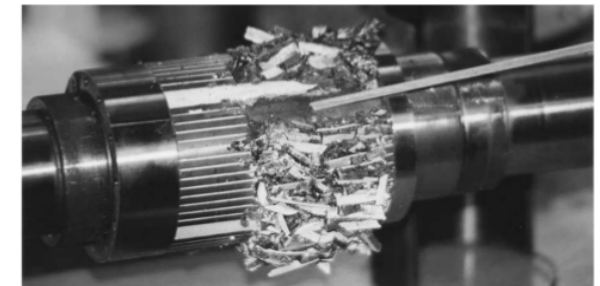

Mechanical behaviour

Picture from: A. Binder, T. Schneider, et M. Klohr, « Fixation of buried and surface-mounted magnets in high-speed permanent-magnet synchronous machines », IEEE Trans. on Ind. Applicat., vol. 42, n° 4, p. 1031-1037, juill. 2006, doi: 10.1109/TIA.2006.876072.



- Induction and Permanent Magnet Synchronous Machine will be studied as they are more adapted for high-speed operation

Induction motor

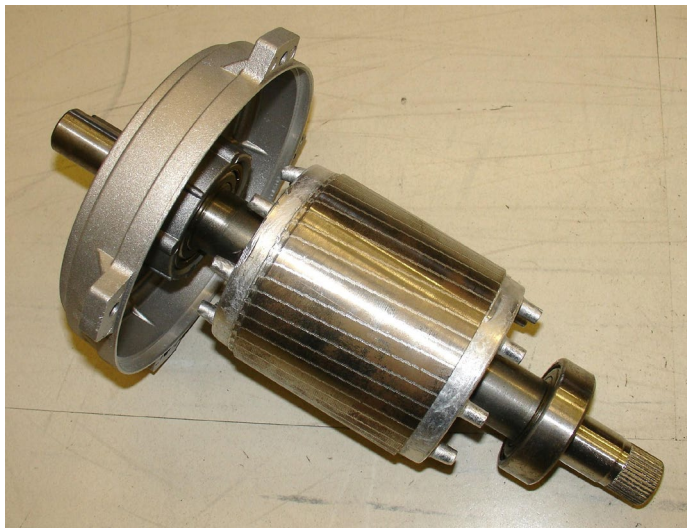

Picture from : en.wikipedia.org/wiki/Squirrel-cage_rotor

Permanent magnet synchronous machine



Picture from : <https://hal.archives-ouvertes.fr/hal-01065265/document>, Etude des pertes par courants induits dans les deux frettes, une composite et une à base d'alliage métallique, d'une machine synchrone rapide à aimants permanents

- I. Introduction
- II. Analytical modeling of a solid rotor and PMSM
- III. Finite Element modelisation
- IV. Comparison of the results
- V. Conclusion

Objective:

- Develop simple analytical models **WHY ?**
 - For rapid mechanical pre-sizing of machines
 - To allow therefore optimization procedures



How mechanical handling is defined ?

- Various yield criteria used in the literature:
 - ↳ Von Mises (σ_{VM}) or Tresca (σ_T) equivalent stresses
- Plasticity criteria respected if
 - ↳ $\sigma_{VM} = \frac{1}{\sqrt{2}} \sqrt{(\sigma_I - \sigma_{II})^2 + (\sigma_{II} - \sigma_{III})^2 + (\sigma_{III} - \sigma_I)^2} \leq \sigma_e$ or
 $\sigma_T = \max(|\sigma_I - \sigma_{II}|, |\sigma_{II} - \sigma_{III}|, |\sigma_I - \sigma_{III}|) \leq \sigma_e$ with σ_e the material yield strength

Analytical modeling of a rotor

- First approach:

Plane Stress approach

Considers a **thin disk**

↳ only $\sigma_{rr}(r)$ and $\sigma_{\theta\theta}(r)$

OR

$\sigma_{rr}(r, z)$ and $\sigma_{\theta\theta}(r, z)$

limit case

Lead to a 3D strain tensor

↳ ϵ_{rr} , $\epsilon_{\theta\theta}$ and ϵ_{zz}

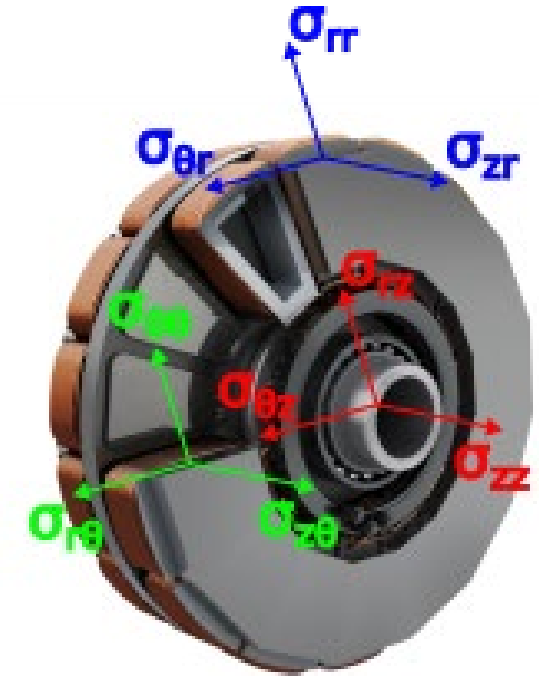

Picture from:
www.greencarcongress.com/2021/11/20211124-whydot.html

- Second approaches:

Field displacement approach

Considers a long cylinder

↳ only $u_r(r)$ and $u_z(z)$

Lead to a 3D stress tensor

↳ $\sigma_{rr}, \sigma_{\theta\theta}$ and σ_{zz}

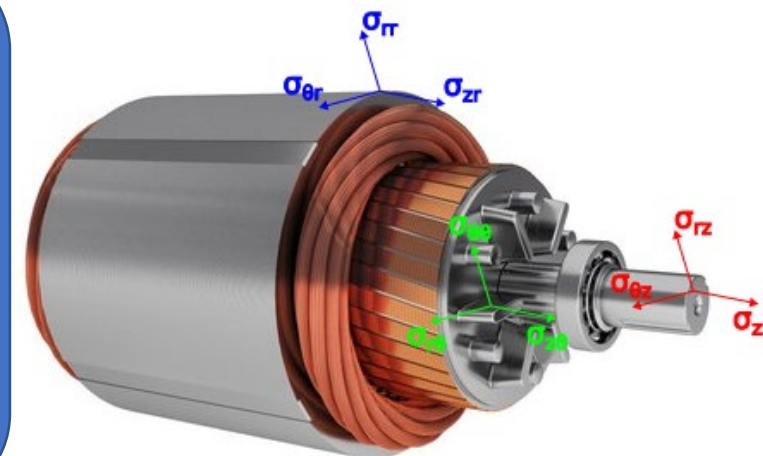

Picture from: www.cgtrader.com/3d-models/industrial/industrial-machine/electric-motor-rotor-stator

- Isotropic linear elastic materials characteristics:

↳ Hooke's law:

$$\underline{\underline{\sigma}} = \lambda \text{Tr}(\underline{\underline{\epsilon}}) \underline{\underline{I}} + 2\mu \underline{\underline{\epsilon}}$$

With (λ, μ) Lamé's coefficient

Solid and hollow cylinder

Field displacement approach ($H/r \gg 1$):

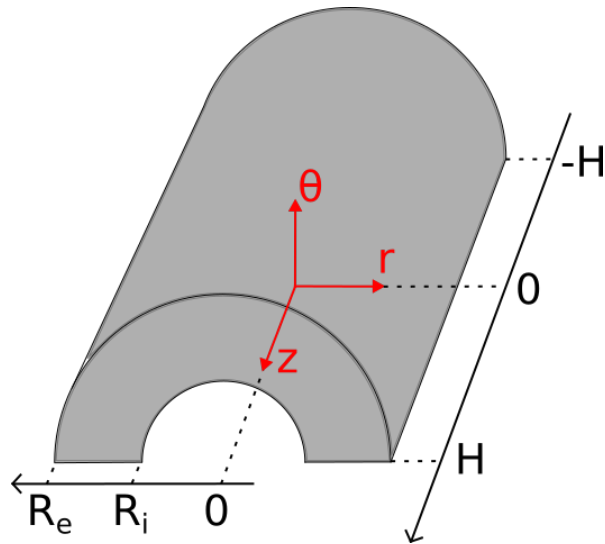

• Solid rotor



$$\begin{cases} \sigma_{rr} = \frac{\rho v^2}{8} \frac{3 - 2\vartheta}{1 - \vartheta} \left(1 - \frac{r^2}{R_e^2} \right) \\ \sigma_{\theta\theta} = \frac{\rho v^2}{8(1 - \vartheta)} \left((3 - 2\vartheta) - (1 + 2\vartheta) \frac{r^2}{R_e^2} \right) \\ \sigma_{zz} = \frac{\rho v^2}{4} \frac{\vartheta}{1 - \vartheta} \left(1 - 2 \frac{r^2}{R_e^2} \right) \end{cases}$$

• Hollow rotor



Long formulas found with Matlab
Symbolic calculation toolbox

Hollow disk with internal pressure

Plane Stress : Thin Disk

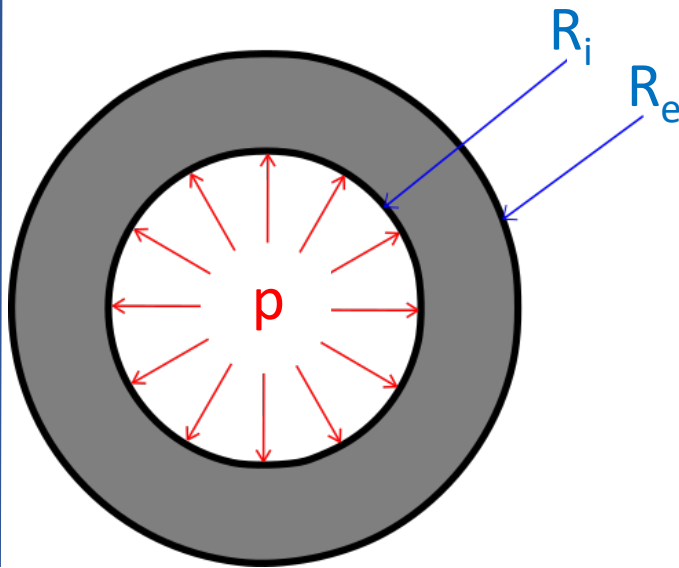

$$\begin{cases} \sigma_{rr}(r) = \frac{\rho\omega^2(3+\nu)}{8.r^2} [(R_i^2 - r^2)(r^2 - R_e^2)] + p \cdot \left[-1 - \frac{R_e^2}{R_i^2 - R_e^2} + \frac{R_i^2 \cdot R_e^2}{(R_i^2 - R_e^2) \cdot r^2} \right] \\ \sigma_{\theta\theta}(r) = \frac{\rho\omega^2 r^2}{8} \left[(3+\nu) \cdot \left(\frac{R_i^2 + R_e^2}{r^2} + \frac{R_i^2 \cdot R_e^2}{r^4} - (1+3\nu) \right) \right] - p \cdot \left[1 + \frac{R_e^2}{R_i^2 - R_e^2} + \frac{R_i^2 \cdot R_e^2}{(R_i^2 - R_e^2) \cdot r^2} \right] \end{cases}$$

Plane Stress : Thin Disk

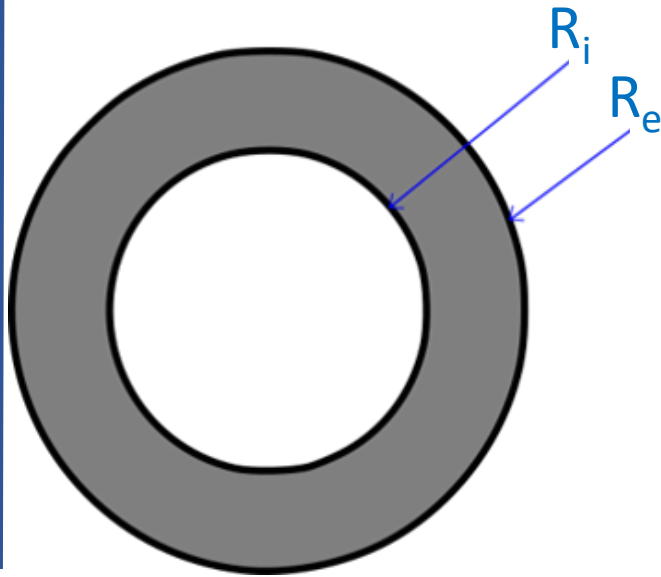

Only r dependency

$$\begin{cases} \sigma_{rr}(r) = \frac{\rho\omega^2(3+\nu)}{8 \cdot r^2} [(R_i^2 - r^2)(r^2 - R_e^2)] \\ \sigma_{\theta\theta}(r) = \frac{\rho\omega^2 r^2}{8} \left[(3+\nu) \cdot \left(\frac{R_i^2 + R_e^2}{r^2} + \frac{R_i^2 \cdot R_e^2}{r^4} - (1+3\nu) \right) \right] \end{cases}$$

r dependency and z dependency

$$\begin{cases} \sigma_{rr}(r, z) = \frac{-\rho\omega^2(3+\nu)}{8r^2} (r^2 - R_i^2)(r^2 - R_e^2) + \frac{\rho\omega^2\nu(1+\nu)}{2(1-\nu)} \left(\frac{H^2}{3} - z^2 \right) \\ \sigma_{\theta\theta}(r, z) = \frac{-\rho\omega^2}{8r^2} \left[(1+3\nu)r^4 - (3+\nu) \left((R_i^2 + R_e^2)r^2 + R_i^2 R_e^2 \right) \right] + \frac{\rho\omega^2\nu(1+\nu)}{2(1-\nu)} \left(\frac{H^2}{3} - z^2 \right) \end{cases}$$

Plane Stress : Thin Disk

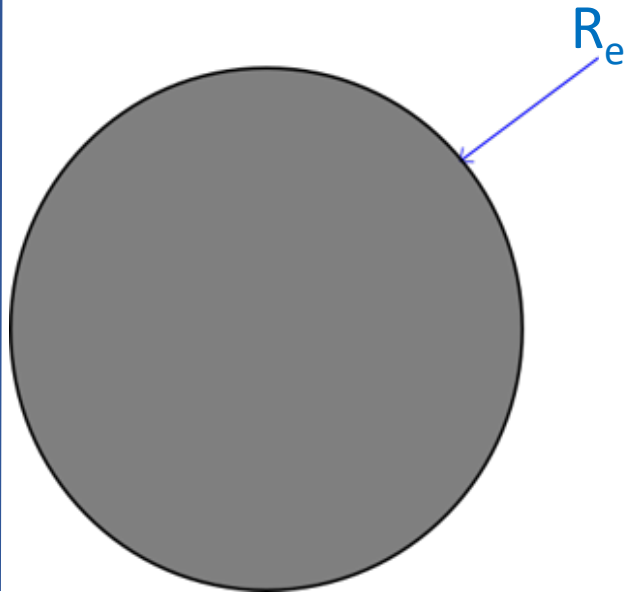

r dependency

$$\begin{cases} \sigma_{rr}(r) = \frac{\rho\omega^2(3+\nu)}{8} (R_e^2 - r^2) \\ \sigma_{\theta\theta}(r) = \frac{\rho\omega^2}{8} \left((3 + \nu)R_e^2 - (1 + 3\nu)r^2 \right) \end{cases}$$

r and z dependency

$$\begin{cases} \sigma_{rr}(r, z) = \frac{-\rho\omega^2(3 + \nu)}{8} (r^2 - R_e^2) + \frac{\rho\omega^2\nu(1 + \nu)}{2(1 - \nu)} \left(\frac{H^2}{3} - z^2 \right) \\ \sigma_{\theta\theta}(r, z) = \frac{\rho\omega^2}{8} \left[(3 + \nu)R_e^2 - (1 + 3\nu)r^2 \right] + \frac{\rho\omega^2\nu(1 + \nu)}{2(1 - \nu)} \left(\frac{H^2}{3} - z^2 \right) \end{cases}$$

Case of two layers disk

- Goal : determine pressure between materials due to mechanical interference between them

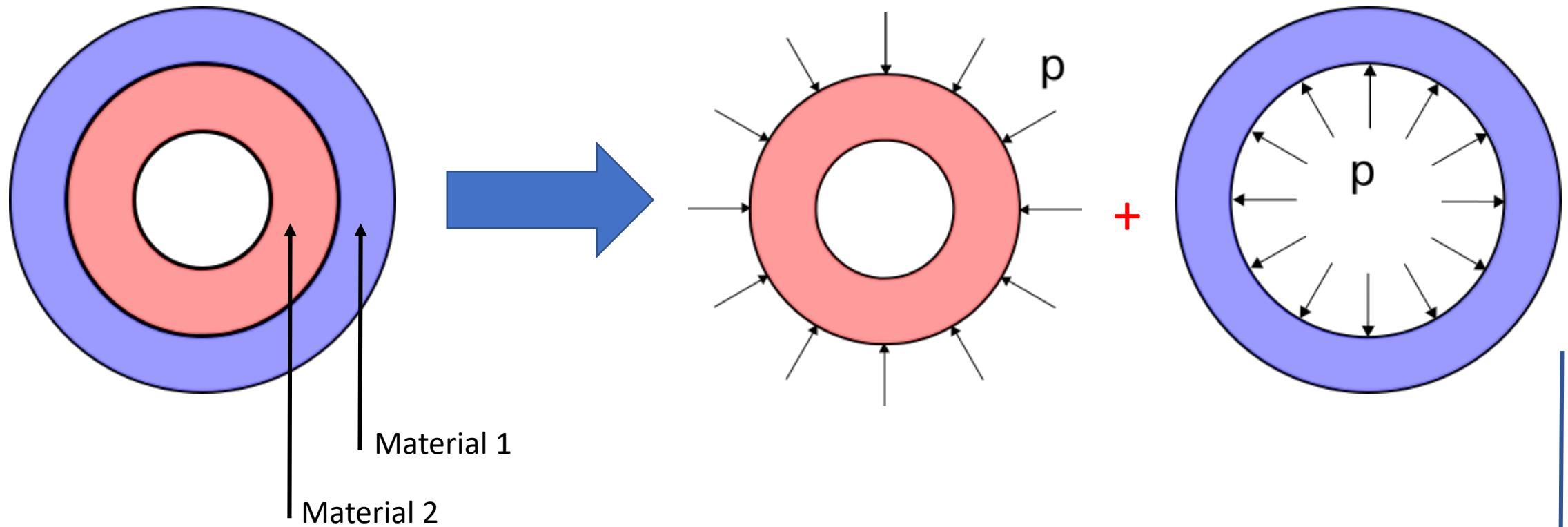

Stress calculation : pressure method

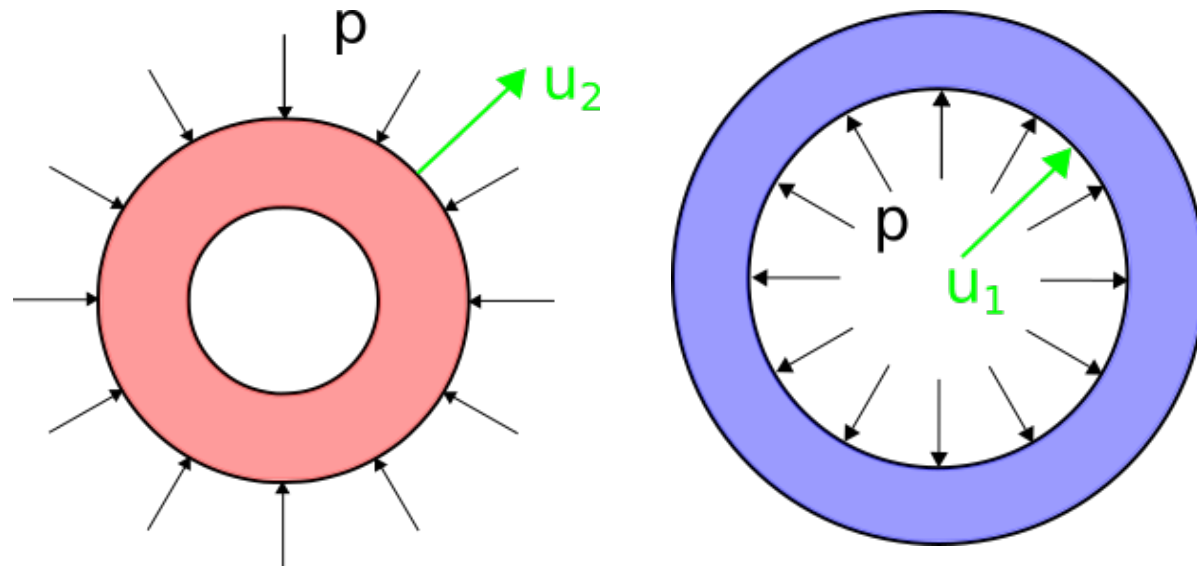

Continuity of the displacement field :

○ $p \rightarrow u_1 = u_2$

1. Calculation of the displacement of each ring, with pressures as parameters
2. Continuity of the displacement field
3. Determination of the pressures and thus of the pre-stress
4. Identification of the stresses in the external ring

Stress calculation : displacement method

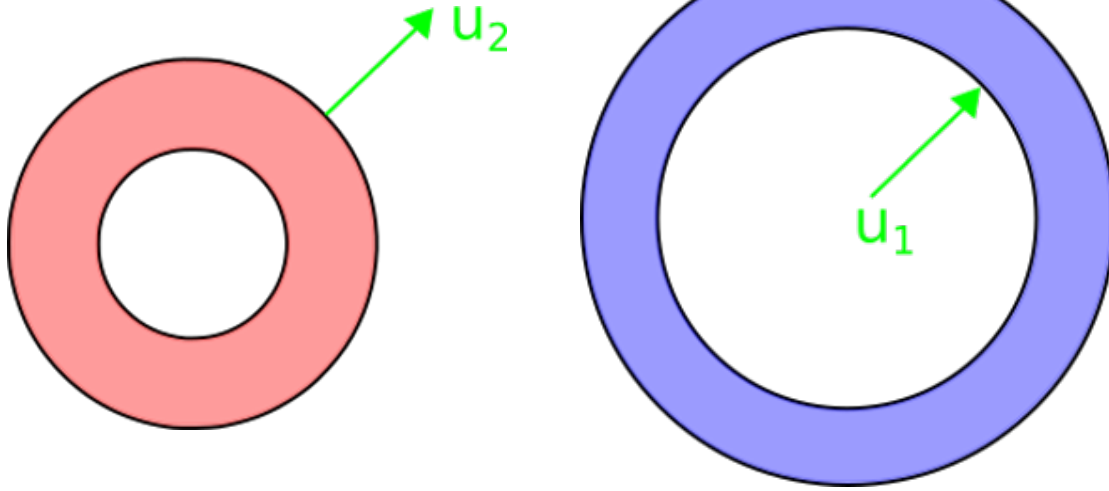

Mechanical interference :

- $E1 = u1 - u2$

1. Calculation of the displacement of each free ring
2. Calculation of the mechanical interference between each ring
3. Calculation of the pressure

Stress calculation : superposition method

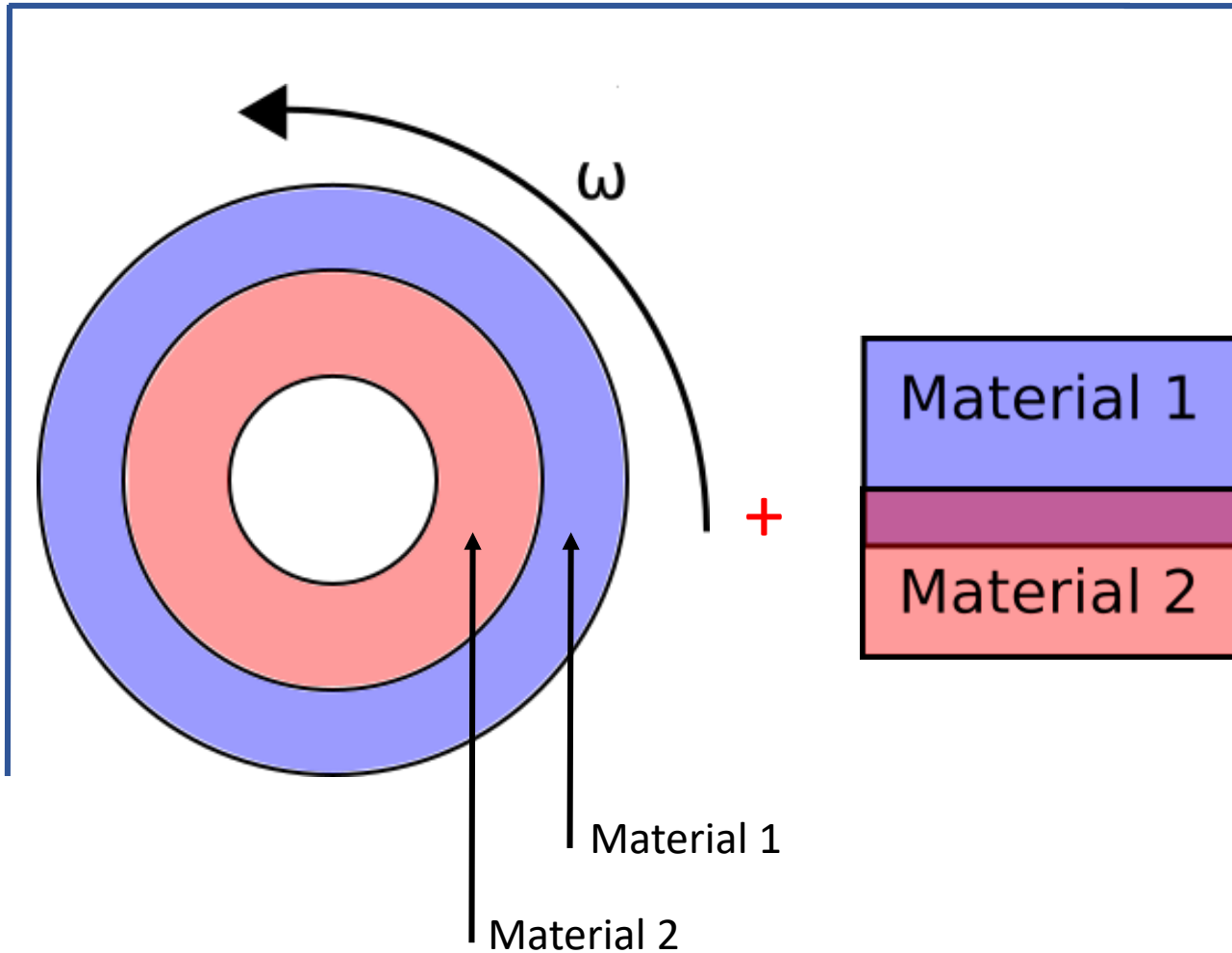

1. Calculation of stresses caused by centrifugal forces only
2. Calculation of stresses caused by force fit
3. Sum of the two stress tensors

- Applications of the models to different topologies:

Solid rotor in steel

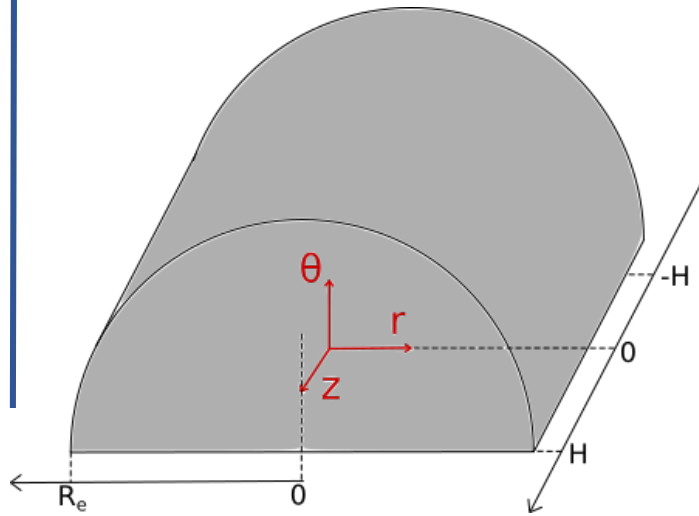

Hollow rotor in steel

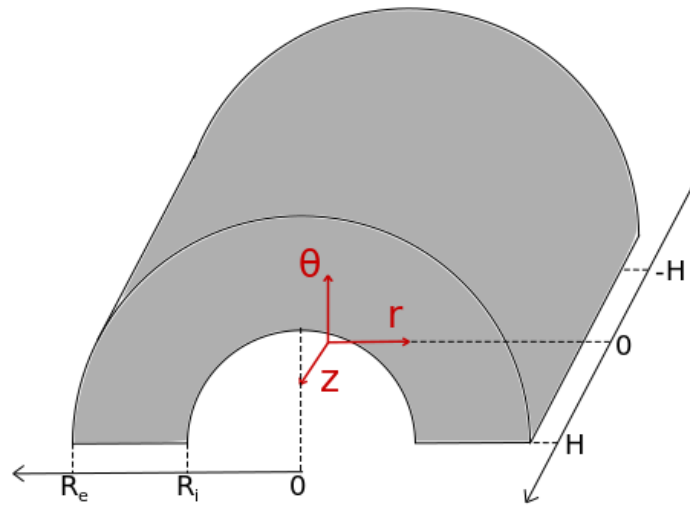

PMSM's rotor

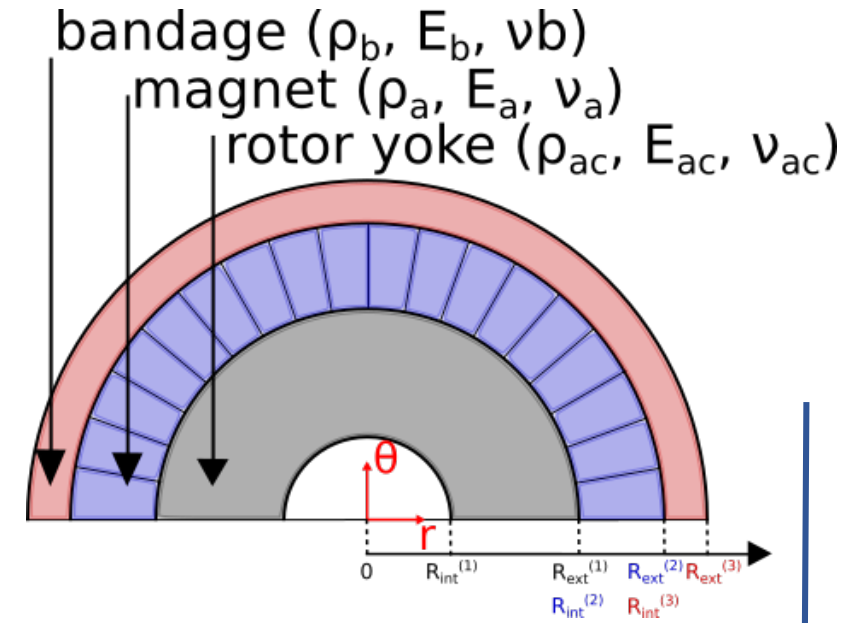

- 2D and 3D finite element simulation (Abaqus software)
- Materials characteristics : same as the analytical models
- Boundary conditions:

$\left\{ \begin{array}{l} \text{at } x = 0 \text{ no displacement along } x - \text{ direction} \\ \text{at } y = 0 \text{ no displacement along } y - \text{ direction} \end{array} \right.$

- Mesh: triangle mesh (2D) and tetrahedrons (3D) to avoid hourglass modes

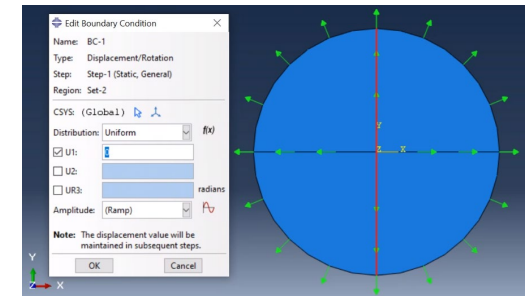
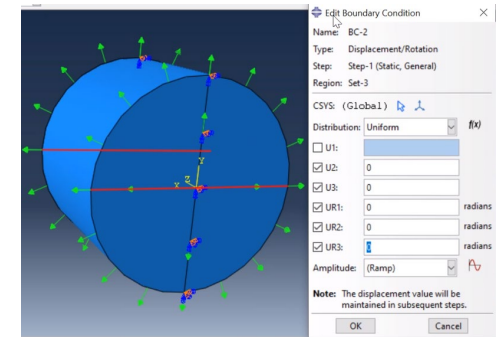
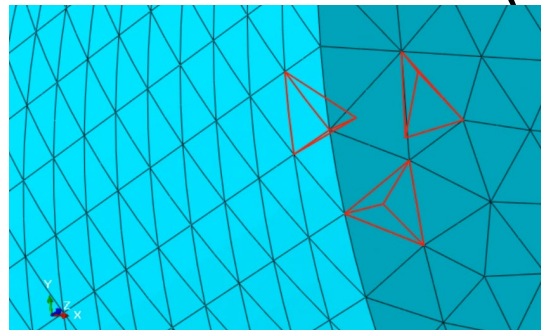

Numerical modeling of PMSM rotor

- Finite element simulation (Abaqus software)
- Similar approach to previous studies (Solid Disk)
- Two finite element models:
 - Only the sleeve with internal pressure
 - Complete rotor with mechanical interference modelling

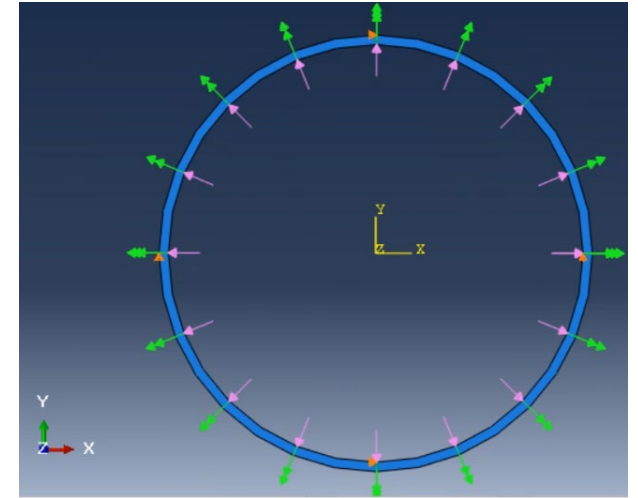

Analysis of the results for a hollow rotor

Simulated case: $\Omega = 30.000 \text{ rpm}$ $v=200 \text{ m/s}$, $R_i = 24.2 \text{ mm}$,

↳ Sizing of 200 kW machine $R_e = 65.7 \text{ mm}$ and $H = 50 \text{ mm}$

Tresca's stress evolution in $z=1 \text{ mm}$ for a hollow disk with $R_i=24.2 \text{ mm}$

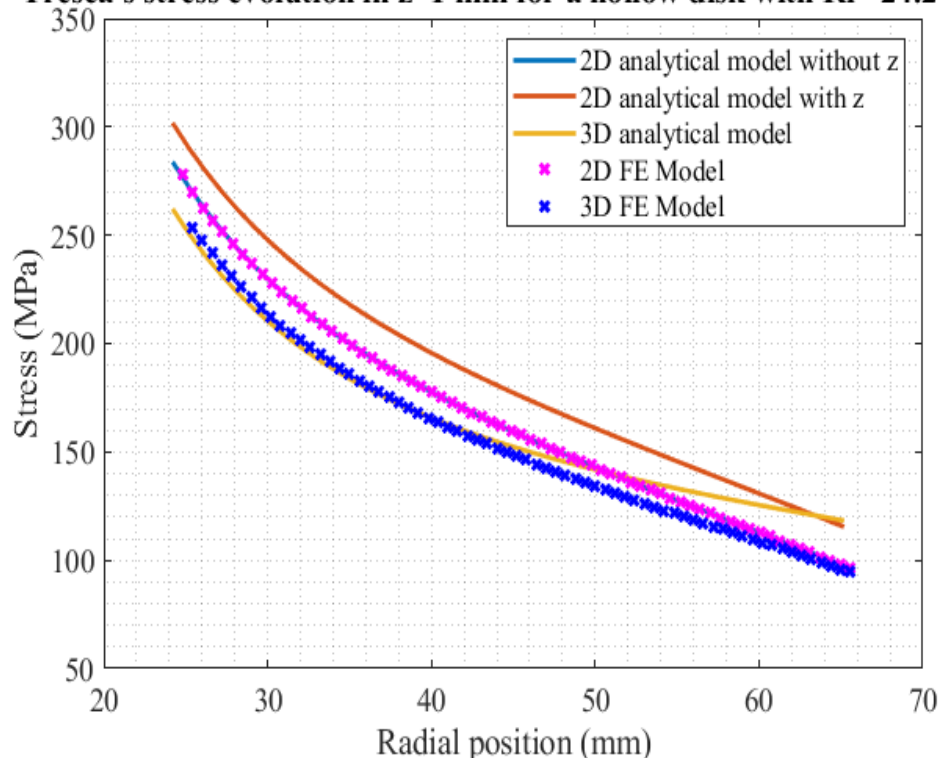

- Yield strength of the steel = 400 MPa
↳ Mechanical handling

N.B: maximum stresses at the center

- For 2D stress tensor:
↳ Exact matching of models and 9% overestimation in model with z
- For 3D stress tensor:
↳ Matching of the models along the radius excepted at the end

Analysis of the results for a solid rotor

Simulated case: $\Omega = 30.000 \text{ rpm}$ $v=200 \text{ m/s}$, $R_i = 24.2 \text{ mm}$,
 $R_e = 65.7 \text{ mm}$ and $H = 50 \text{ mm}$

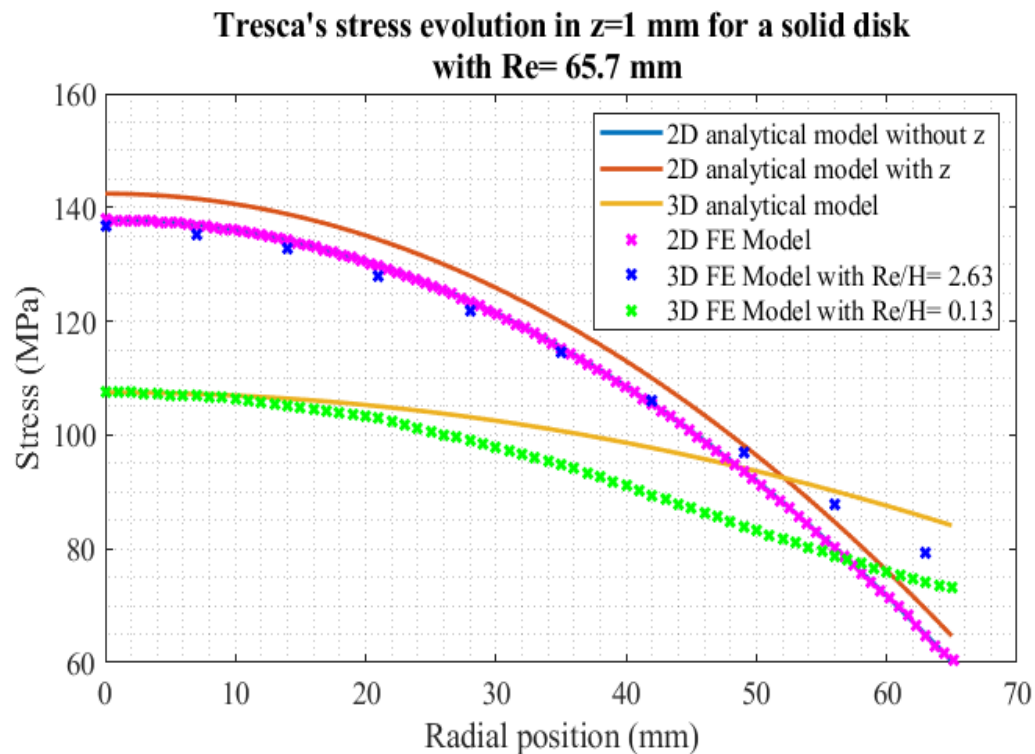

- Same remarks as the hollow disk
- +
- For 3D stress tensor:
 - ↳ Matching of the models depending on the slenderness of the rotor

N.B:

$$\sigma_{Tmax}(hollow) \approx 2\sigma_{Tmax}(solid)$$

Visualisation of the stresses in the sleeves

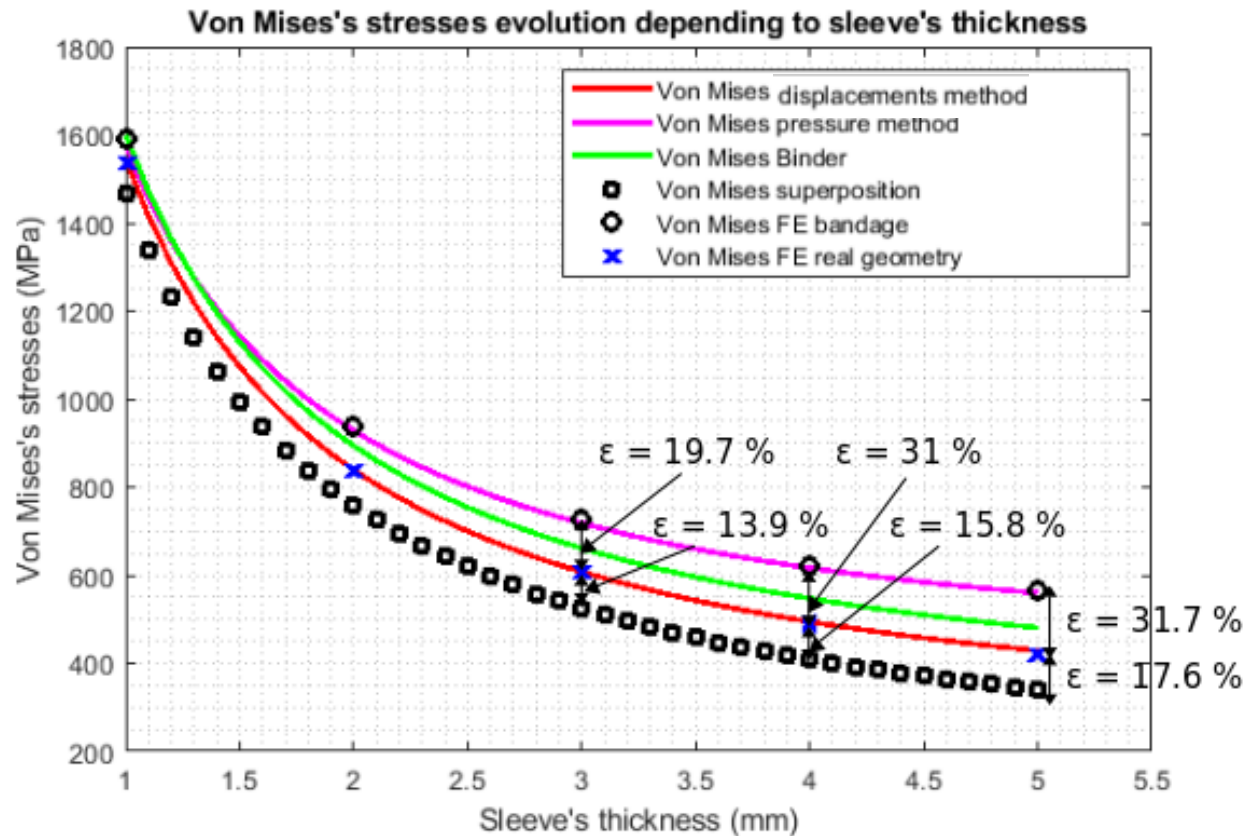

- Matching of the analytical and numerical results
- Finite element model of the real geometry taken as reference

- Simple analytical models were studied and gives relevant results
- Best models :
 - PMSM : displacement method
 - Solid and hollow rotor : 2D analytical
- Optimization operation can now easily be done with this models, CPU time saving (5000 times)
- Mutliphysic design of high-speed machine can further be developed



Université de Lorraine - UR 4366
Pôle Scientifique « Energie Mécanique Procédés produits »
Groupe de Recherche en Energie et Electrique de Nancy

Merci pour votre attention

QUESTIONS

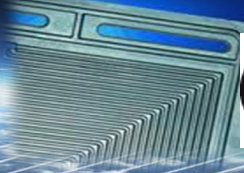
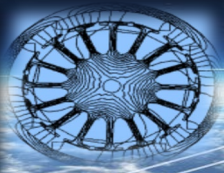

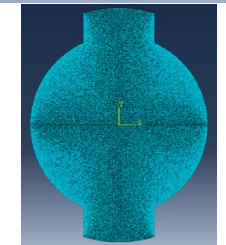
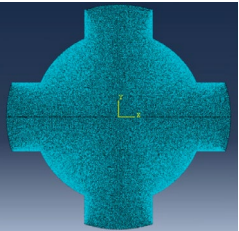
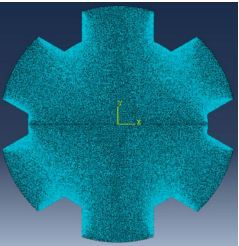
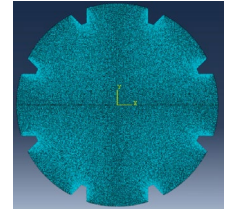

Influence of rotor plots number on the stresses

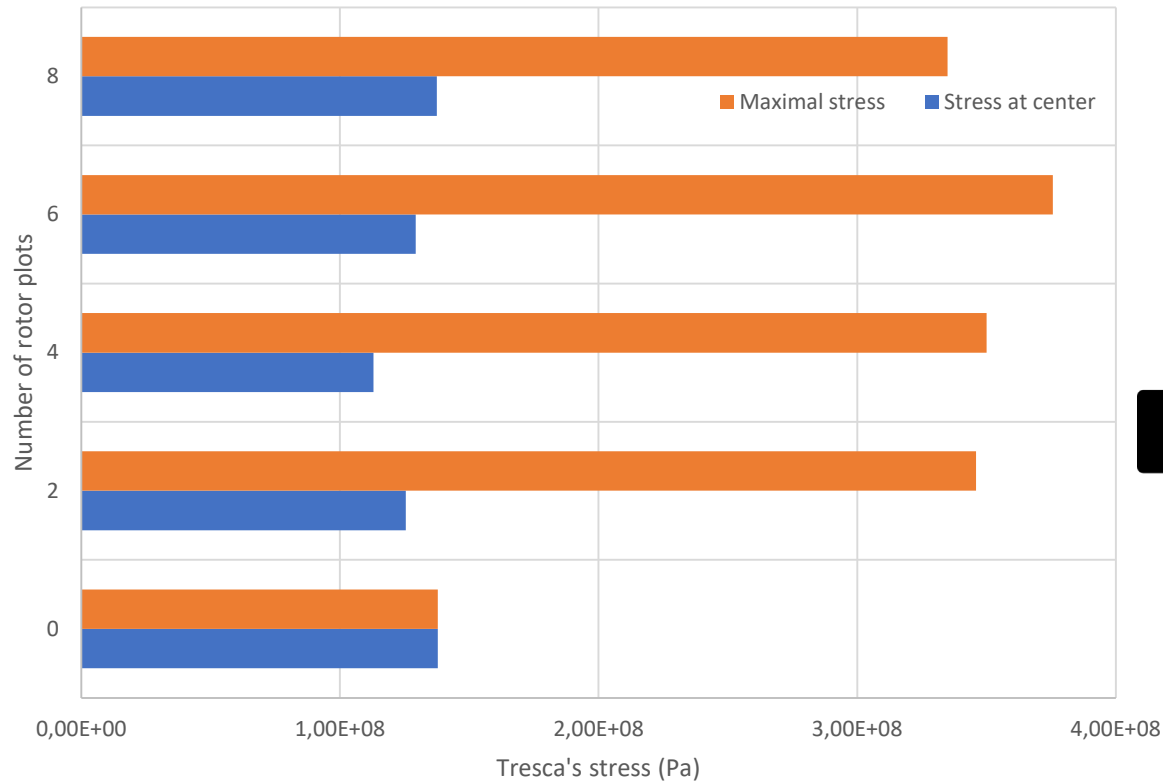

1. Weak influence of rotor plots number on the stresses
2. Maximal stresses are now located in the discontinuous places of the rotor (edges)

Maximal stress depending on magnets opening

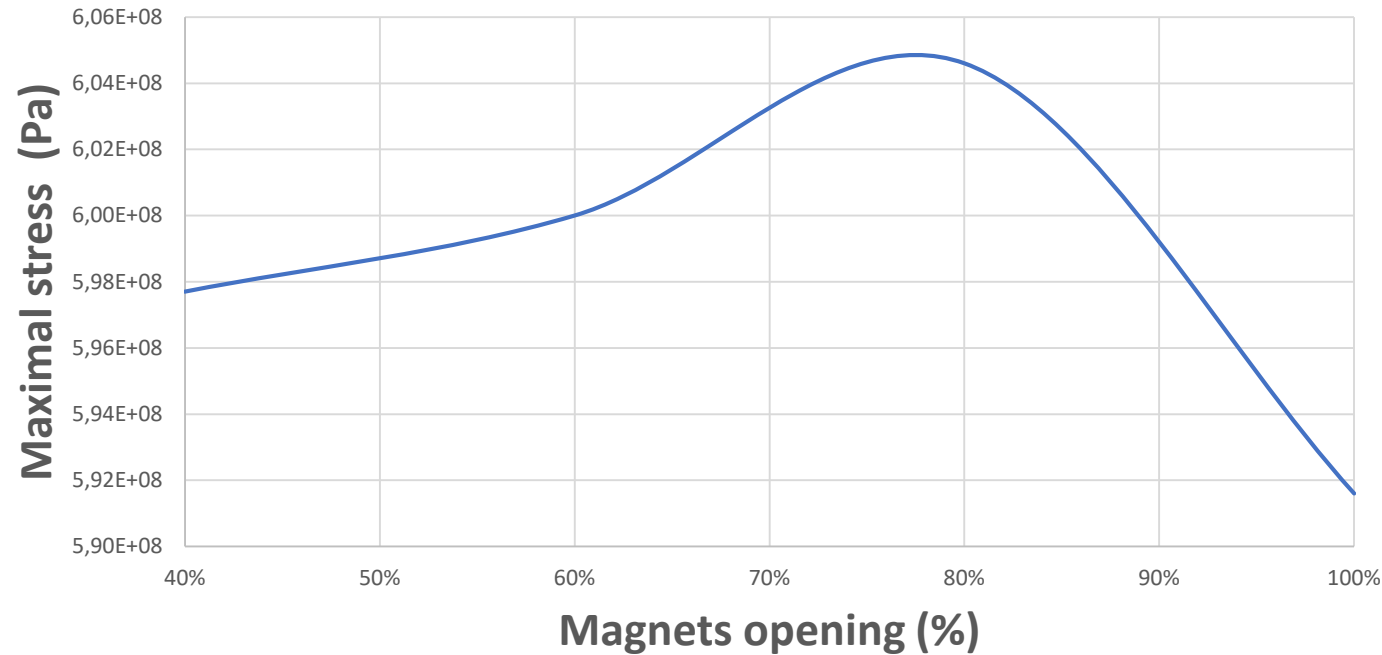

1. Magnet opening influence can be neglected for this topology (<2%)
2. Three-layer model is good for mechanical sizing

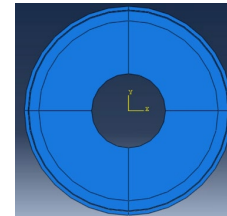
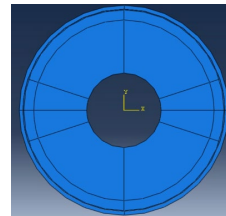
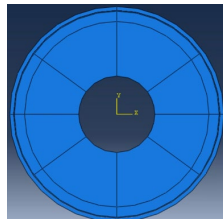
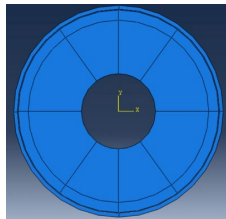

Tresca's stress along z axis at the center depending on rotor length

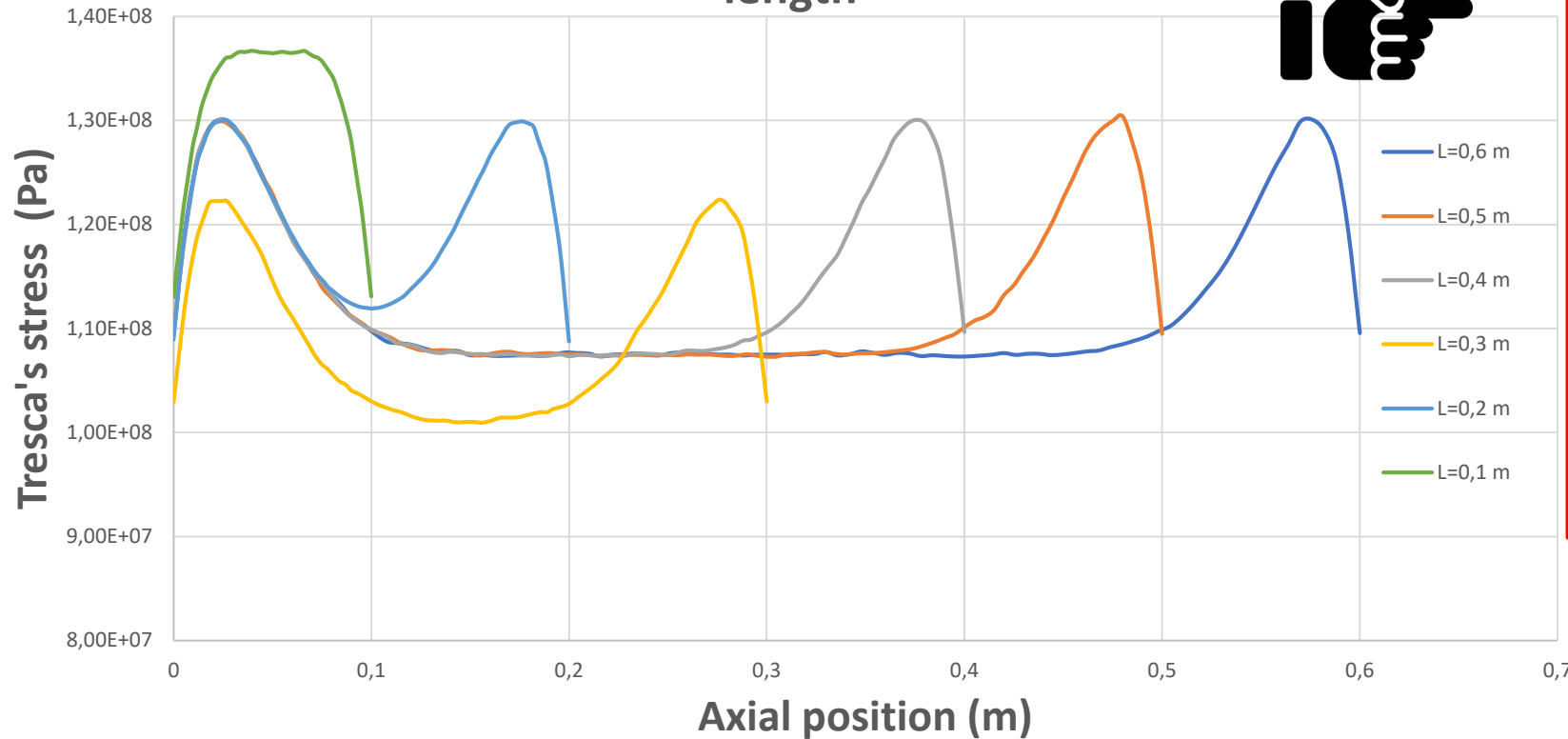

1. A very slight influence of the stress respecting to axial length
2. 2D models based mechanical sizing are sufficient (3-5% oversize)

